

Operator's Manual

HomeFill™ II Compressor

APPROVED

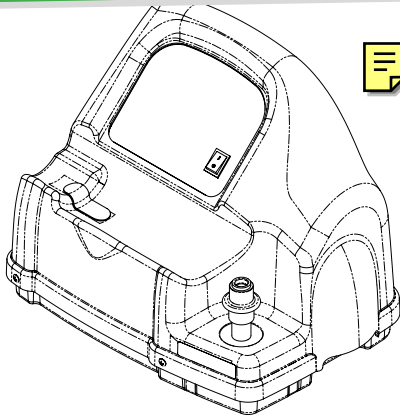

User: Before using the product, read this manual and save for future reference.

Dealer: This manual must be given to the end user.

For more information regarding
Invacare products, parts, and services,
please visit www.invacare.com



Yes, you can.

⚠ WARNING

DO NOT OPERATE THIS EQUIPMENT WITHOUT FIRST READING AND UNDERSTANDING THIS MANUAL. IF YOU ARE UNABLE TO UNDERSTAND THE DANGERS, WARNINGS, CAUTIONS, AND INSTRUCTIONS, CONTACT INVACARE TECHNICAL SERVICES BEFORE ATTEMPTING TO USE THIS EQUIPMENT - OTHERWISE, SERIOUS INJURY OR PROPERTY DAMAGE MAY RESULT.

NOTICE

The information contained in this document is subject to change without notice.

⚠ WARNING

Users MUST NOT SMOKE while using this device. Keep all matches, lighted cigarettes or other sources of ignition out of the room in which this product is located. Textiles and other materials that normally would not burn are easily ignited and burn with great intensity in oxygen enriched air. Failure to observe this warning can result in severe fire, property damage and cause physical injury or DEATH.

NOTE: Updated versions of this manual are available on www.invacare.com.

TABLE OF CONTENTS

SPECIAL NOTES 4

TYPICAL PRODUCT 5

PARAMETERS 5

LABEL LOCATION 6

DEALER INFORMATION 6

HOMEFILL II INFORMATION 7

SECTION 1—IMPORTANT SAFETY

INSTRUCTIONS 8

 Servicing of Double-Insulated Products..... 11

SECTION 2—INITIAL SETUP 12

 Initial Set Up of Compressor..... 12

SECTION 3—CHECKLIST AND CYLINDER

INSPECTION 16

 Compressor Operation Checklist..... 16

 Cylinder Prefill Inspection..... 16

SECTION 4—COMPRESSOR OPERATION 23

 Connecting/Disconnecting the Cylinder to/from the
 Compressor..... 23

 Turning the Compressor On 29

 Setting the Flow Knob to the Prescribed Setting 31

SECTION 5—INDICATOR LIGHTS 32

SECTION 6—TROUBLESHOOTING/ CYLINDER

FILL TIMES 34

SECTION 7—MAINTENANCE 37

 Cleaning the Compressor Filter 37

 Cabinet 38

LIMITED WARRANTY 38

SPECIAL NOTES

Check all parts for shipping damage. In case of damage, DO NOT use. Contact Invacare for further instruction.

Signal words are used in this manual and apply to hazards or unsafe practices which could result in personal injury or property damage. Refer to the following table for definitions of the signal words.

SIGNAL WORD	MEANING
DANGER	Danger indicates an imminently hazardous situation which, if not avoided, will result in death or serious injury.
WARNING	Warning indicates a potentially hazardous situation which, if not avoided, could result in death or serious injury.
CAUTION	Caution indicates a potentially hazardous situation which, if not avoided, may result in property damage.

ACCESSORIES

There are many different types of humidifiers, oxygen tubing, cannulas and masks that can be used with this device. You should contact your local home care provider for recommendations on which of these devices will be best for you. They should also give you advice on the proper usage, maintenance, and cleaning.

WARNING

Invacare products are specifically designed and manufactured for use in conjunction with Invacare accessories. Accessories designed by other manufacturers have not been tested by Invacare and are not recommended for use with Invacare products.

TYPICAL PRODUCT PARAMETERS

Regulatory Listing:	Double Insulated Product
	ETL Certified Complying with UL73 and ULI097 (US)
	ETL Certified Complying with CAN/CSA C22.2 No. 68 (Canada)
	For household use only.

TYPICAL PRODUCT PARAMETERS - COMPRESSOR

Operating temperature:	50 to 95° F (10 to 35° C) @ 20 to 60% non-condensing humidity
Storage temperature:	-10 to 150° F (-23 to 65° C) @ 15 to 95% humidity
Input Pressure Required:	14 - 21 psi
Input Flow Required:	2 L/min
Input O₂% Required:	>90% O ₂
Width:	20 ¼ inches
Height:	15 inches
Depth:	16 inches
Weight:	33 lbs
Shipping Weight:	39 lbs

LABEL LOCATION

⚠ WARNING
Keep all connections free of oil and grease to avoid violent ignition. See Owner's Manual before cleaning. P/N 1075220 Rev C - 10/04

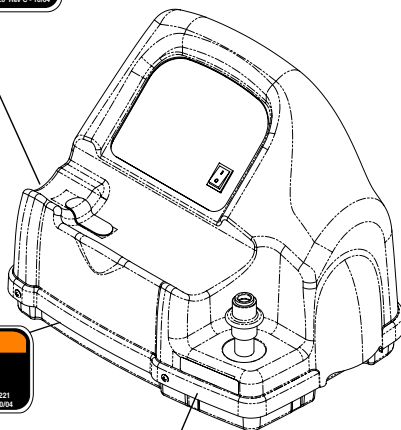

⚠ WARNING
DO NOT REMOVE UNIT COVER
This unit contains moving and high pressure components. Manufacturer Service Only. P/N 1075221 Rev B - 10/04

⚠ WARNING
Keep all connections free of oil and grease. See Owner's Manual before cleaning. Cylinders filled on this unit must be labeled "Contents of this cylinder are the product of an oxygen concentrator." P/N 1075220 Rev B - 10/04

DEALER INFORMATION

NOTE: Invacare recommends leaving a full cylinder of oxygen with the patient after setting up the HomeFill II compressor.

Before leaving a HomeFill II Compressor with a user, the following checklist **MUST** be completed:

- Make sure the pressure test on cylinder has not expired.
- Instruct the user on the safe operation of the concentrator and review all warnings.
- Instruct the user on the safe operation of the HomeFill II compressor and review all warnings.
- Leave a full cylinder of oxygen with the user.
- Leave a copy of all warnings and filling instructions with the user.

HOMEFILL II INFORMATION

HomeFill II is an accessory device to the oxygen concentrator that enables the patient to refill custom portable oxygen cylinders for personal use.

NOTICE

The HomeFill II compressor is for use with specially designed Invacare Platinum™ 5, 10 and XL HomeFill II compatible oxygen concentrators.

The oxygen concentrator can be set to the following maximum flowrates when operating with HomeFill II compressor:

Platinum 5 and XL: 3 L/min. or less.

Platinum 10: 5 L/min. or less.

To determine if your oxygen concentrator is HomeFill II compatible, examine the lower right corner of the rear of the oxygen concentrator for an outlet fitting. Refer to the illustration below.

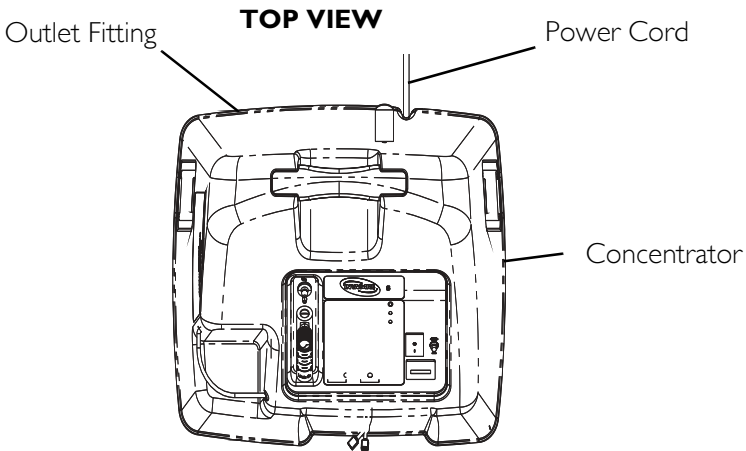

SECTION I—IMPORTANT SAFETY INSTRUCTIONS

⚠ WARNING

SECTION I - IMPORTANT SAFETY INSTRUCTIONS contains important information for the safe operation and use of this product. **DO NOT** use this product or any available optional equipment without first completely reading and understanding these instructions and any additional instructional material such as **Owner's Manuals, Service Manuals or Instruction Sheets** supplied with this product or optional equipment. If you are unable to understand the **Warnings, Cautions or Instructions**, contact a health care professional, dealer or technical personnel before attempting to use this equipment - otherwise, injury or damage may occur.

CAUTION

“Caution: Federal law restricts this device to sale by or on order of a physician, or any other practitioner licensed by the law of the State in which he/she practices to use or order the use of this device.”

When using the HomeFill II, basic precautions should ALWAYS be followed, including the following:

⚠ WARNING

TO REDUCE THE RISK OF BURNS, ELECTROCUTION, FIRE, OR INJURY TO PERSONS.

NEVER use near any type of flame or flammable/explosive substances, vapors or atmosphere.

DO NOT allow oil from your hands or other sources to come into contact with the compressor coupling or bottle fittings. These substances may become flammable in the presence of oxygen and cause injury. Avoid touching the bottle fitting whenever possible. Example of items to avoid are hand creams or lotions, cooking oils, suntan oils or sunblocks and similar oily products. If you use these types of products Invacare suggests you wash your hands prior to using the HomeFill unit. If the bottle fitting should come in contact with such substances it should be cleaned off with a damp cloth prior to connecting it to the compressor.

NEVER oil or lubricate the compressor coupler or bottle fittings. NEVER use any penetrating oil or lubricant such as WD-40 or 3 in One. If connection difficulty is experienced verify that the bottle fitting is being inserted straight down into the compressor coupler. If continued difficulty is experienced contact your supplier for assistance.

Before moving or repositioning either the compressor or concentrator, ALWAYS push the power switch to the Off (O) position, disconnect the AC power cord and the interconnect hose between the compressor and concentrator. Failure to do so may result in damage to the unit or personal injury.

Children should ALWAYS be supervised around the HomeFill II unit. When used with the HomeFill table or similar elevated support surfaces, a child could pull over any such table causing the unit to fall. Failure to observe this warning may result in personal injury or product damage.

Use extreme care when handling and filling an oxygen cylinder. Full oxygen cylinders are under pressure and can become a projectile if dropped or mishandled.

NEVER transport a compressor with a cylinder connected to or stored on the compressor, otherwise injury or damage can occur.

DO NOT store filled oxygen cylinders near a furnace, hot water tank, in the trunk of a car or other high temperature area. Storage in areas such as this can result in bursting of the cylinder or fire.

The use of this device is limited to the oxygen patient. Cylinders MUST be used ONLY by the oxygen patient and are not to be distributed to any other individual for any purpose.

Invacare products are specifically designed and manufactured for use in conjunction with Invacare accessories. Accessories designed by other manufacturers have not been tested by Invacare and are not recommended for use with Invacare products.

DO NOT use outdoors.

The maximum patient flow while filling cylinders with the IOH200 is 3 L/min. for Platinum 5 and XL, 5 L/min. for Platinum 10. Patients with a higher prescribed flow should not transfill while receiving supplemental oxygen treatment from the Platinum Concentrator.

NEVER block the air openings of the product or place it on a soft surface, such as a bed or couch, where the air opening may be blocked. Keep the openings free from lint, hair and the like.

DO NOT disassemble. The unit is provided with double insulation and has no serviceable parts. Refer to Servicing of Double-Insulated Products on page 11. If any service is required, contact Invacare Technical Service.

If the compressor has a damaged cord or plug, if it is not working properly, if it has been dropped or damaged, or submersed in water, call a qualified technician for examination and repair.

If any leakage of the oxygen cylinder is detected DO NOT attempt to use the cylinder. Turn the flow selector knob on the regulator to Off. If leakage persists, place the cylinder outdoors and notify your Home Health Care Provider or Service Representative of this condition.

The HomeFill II is equipped with a high pressure relief valve to ensure the user's safety. When activated, this safety feature will make an extremely loud noise. If this noise occurs, turn the unit Off and contact your Home Health Care Provider or Service Representative.

Unplug unit from outlet when not in use and before cleaning.

This appliance is provided with double insulation. Use only identical replacement parts. Refer to Servicing of Double-Insulated Products on page 11.

Servicing of Double-Insulated Products

In a double-insulated product, two systems of insulation are provided instead of grounding. No grounding means is provided on a double-insulated product, nor is a means for grounding to be added to the product. Servicing a double-insulated product requires extreme care and knowledge of the system, and is to be done only by qualified service personnel. Replacement parts for a double-insulated product MUST be identical to the parts they replace. A double-insulated product is marked with the words "DOUBLE INSULATION" or "DOUBLE INSULATED". The symbol (☐) is also able to be marked on the product.

CAUTION

DO NOT unplug the power cord by pulling on the cord. To unplug, grasp the plug not the cord, otherwise damage may occur.

SAVE THESE INSTRUCTIONS

SECTION 2—INITIAL SETUP

NOTE: Dealers Only - Refer to Dealer Information on page 6 before performing this procedure.

Initial Set Up of Compressor

Compressor Initial Setup Checklist

Before operating the HomeFill II Compressor for the first time, complete the following checklist:

- Choose a location for the compressor.
- Transport the compressor to the desired location.
- Connect the power cord to the compressor.
- Connect the compressor to the concentrator.

Choosing a location

The compressor should be at least three inches away from walls, draperies or furniture to ensure sufficient air flow.

Avoid placing the compressor next to heaters, radiators or hot air registers.

DO NOT use in a closet.

The compressor should sit on a hard flat stable surface, such as a table or the Ready Rack.

⚠ WARNING

NEVER use near any type of flame or flammable/explosive substances, vapors or atmosphere.

Transporting the Compressor

⚠ WARNING

NEVER transport a compressor with a cylinder connected to or stored on the compressor, otherwise injury or damage can occur.

CAUTION

When transporting the compressor, be careful not to bump the compressor or the connectors into obstacles. Otherwise, damage to the compressor may occur.

NOTE: For this procedure, refer to FIGURE 2.1.

1. There are two methods to safely transport the compressor:
 - A. One hand - Grasp the hand grip at the bottom rear of the compressor.
 - B. Two hands - Grasp the hand grips on the sides of compressor.

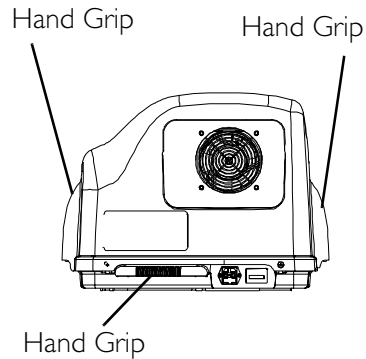

FIGURE 2.1 Transporting the Compressor

Installing the Power Cord

NOTE: For this procedure, refer to FIGURE 2.2 on page 14.

1. Ensure the compressor is on a hard flat stable surface, such as a table or the Ready Rack.
2. Make sure the power switch is in the Off (O) position
3. Plug the power cord into the electric connector in the back of the compressor.

4. Plug the opposite end of the power cord into the wall outlet.

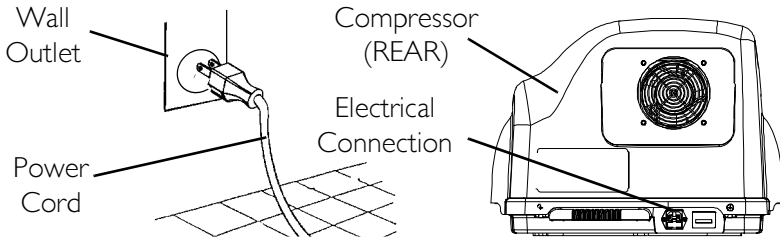

NOTE: This product has a polarized plug (one blade is wider than the other). As a safety feature, this plug will fit in a polarized outlet only one way. If the plug does not fit fully in the outlet, reverse the plug. If it still does not fit, contact a qualified electrician. DO NOT attempt to defeat this safety feature.

FIGURE 2.2 Installing the Power Cord

Connecting the Compressor to the Concentrator

NOTE: For this procedure, refer to FIGURE 2.3 on page 15.

1. Insert one end of the interconnect hose into the outlet fitting on the back of the concentrator (Detail “A”).
2. Insert the opposite end of the interconnect hose into the inlet fitting on the side of the compressor (Detail “B”).

NOTE: The metal tabs on the concentrator outlet fitting and the compressor inlet fitting will pop out with an audible “click” when the end of the interconnect hose is properly installed (Detail “C”).

3. Loop any excess interconnect hose and secure to the back of the concentrator with the fastening straps.

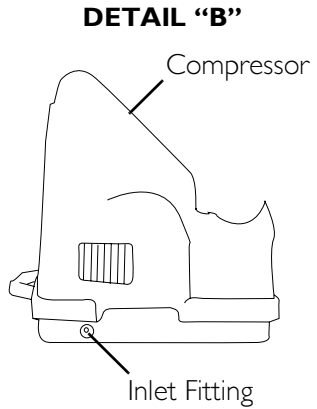
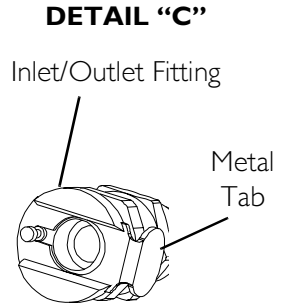
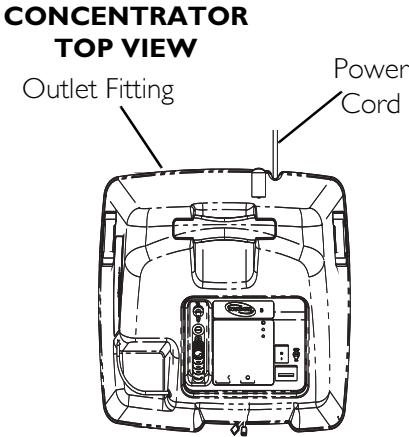
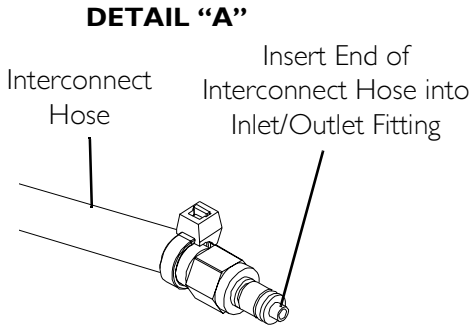

FIGURE 2.3 Connecting the Compressor to the Concentrator

SECTION 3—CHECKLIST AND CYLINDER INSPECTION

Compressor Operation Checklist

Each time the HomeFill II Compressor is used to fill a cylinder, complete the following checklist:

- Ensure the concentrator has been On for at least thirty minutes. Refer to the concentrator Owner's Manual.
- Perform the prefill inspection on the cylinder.
- Connect the cylinder to the compressor.
- Push the compressor power switch to the on (I) position.
- Examine the indicator lights on the control panel.
- Disconnect and remove the full cylinder.
- Push the compressor power switch to the Off (O) position.
- If filling another cylinder, repeat this checklist.

Cylinder Prefill Inspection

WARNING

ONLY use cylinders that have the Invacare HomeFill II connection and the label.

All cylinders MUST be inspected before attempting to fill. Otherwise, injury or damage may occur.

NOTE: For this procedure, refer to FIGURE 3.1 on page 17.

▲ DANGER

Improper filling or abuse of this cylinder, or failure to follow these safety instructions may cause serious bodily injury or death. High pressure oxidizing gas vigorously accelerates combustion.

DO NOT alter or modify cylinder or related components.
DO NOT use Oil or Grease. Keep cylinder, cylinder valve, all equipment and connections free of oil and grease to avoid violent ignition resulting in serious bodily injury or death.

▲ WARNING

For medical applications. Use only as directed by a licensed practitioner. Uninterrupted use of high concentrations of oxygen over a long duration, without monitoring its effect on oxygen content of arterial blood, may be harmful.

Oxygen Cylinders filled by the Venture HomeFill shall be used for personal use only. "Not to be filled for resale or use by professional users".



This cylinder is to be used with the Invacare Venture HomeFill system. This cylinder contains 93 ± 3% oxygen produced by an oxygen concentrator using the pressure swing adsorption process.

DO NOT handle cylinder or use contents until you are professionally trained, including emergency procedures.

Use in accordance with Venture HomeFill Operator's Manual. Open valve slowly. Close valve after each use and when empty. Secure cylinder during storage and use. No smoking in cylinder area. Keep away from heat, flame and spark. Keep out of reach of children. DO NOT drop.

Transfilling of this gas is performed by Venture HomeFill Only.

Cylinders that have been refinished and/or exposed to elevated temperatures must be hydrostatically tested before filling. Cylinder temperature should not exceed 125°F (52°C). Aluminum cylinders subject to the action of fire or heated to temperatures in excess of 350°F must be withdrawn from service and condemned by trained personnel. DO NOT use caustic paint strippers. Valve and safety relief devices must be removed and replaced by trained and authorized personnel. DO NOT alter or change valve assembly.

Invacare Corporation
2101 E. Lake Mary Blvd.
Sanford, FL 32773
1-800-832-4707

DO NOT REMOVE THIS PRODUCT LABEL
Not for Commercial Resale

Part Number 1125090 Rev B - 11/04

FIGURE 3.1 Cylinder Prefill Inspection

The Hydrostatic Testing Date

Aluminum cylinders **MUST** undergo testing every five years.

⚠ WARNING

DO NOT fill cylinders that have not been tested in the past five years. Otherwise, serious personal injury may result. Contact your dealer for replacement.

External Examination

1. Examine the outside of the cylinder for the following conditions, and replace the cylinder if they exist:
 - Dents or dings
 - Arc burns
 - Oil or grease
 - Any other signs of damage that might cause a cylinder to be unacceptable or unsafe for use.
2. Examine the cylinder for evidence of fire or thermal damage. Evidence includes charring or blistering of the paint, or other protective coating or heat sensitive indicator. If fire or thermal damage is found, replace the cylinder.
3. Inspect the cylinder/regulator assembly for the following and replace if found:
 - Debris, oil or grease
 - Noticeable signs of damage
 - Signs of corrosion inside the valve
 - Signs of excessive heat or fire damage

Please Seal with
Tape Before Mailing



REGISTER YOUR PRODUCT!

The benefits of registering:

1. Safeguard your investment.
2. Ensure long term maintenance and servicing of your purchase.
3. Receive updates with product information, maintenance tips, and industry news.
4. Invacare can contact you or your provider, if servicing is needed on your product.
5. It will enable Invacare to improve product designs based on your input and needs.

**Register ONLINE at www.invacare.com
- or -
Complete form and mail.**

Any registration information you submit will be used by Invacare Corporation only, and protected as required by applicable laws and regulations.

PRODUCT REGISTRATION FORM

NAME _____

ADDRESS _____

CITY _____ STATE/PROVINCE _____

ZIP/POSTAL CODE _____

EMAIL _____ PHONE NO. _____

INVACARE MODEL NO. _____

SERIAL NO. _____

PURCHASED FROM _____

DATE OF PURCHASE: _____

1. Method of purchase: (check all that apply)

- Medicare Insurance Medicaid Other

2. This product was purchased for use by: (check one)

- Self Parent Spouse Other

3. Product was purchased for use at:

- Home Facility Other

4. I purchased an Invacare product because:

- Price Features (list features)

5. Who referred you to Invacare products? (check all that apply)

- Doctor Therapist Friend Relative Dealer/Provider Other
 Advertisement (circle one): TV, Radio, Magazine, Newspaper No Referral

6. What additional features, if any, would you like to see on this product?

7. Would you like information sent to you about Invacare products that may be available for a particular medical condition? Yes No

If yes, please list any condition(s) here and we will send you information by email and/or mail about any available Invacare products that may help treat, care for or manage such condition(s):

8. Would you like to receive updated information via email or regular mail about the Invacare home medical products sold by Invacare's dealers? Yes No

9. What would you like to see on the Invacare website?

10. Would you like to be part of future online surveys for Invacare products? Yes No

11. User's Year of birth: _____

If at any time you wish not to receive future mailings from us, please contact us at Invacare Corporation, CRM Department, 39400 Taylor Parkway, Elyria, OH 44035, or fax to 877-619-7996 and we will remove you from our mailing list.

TO FIND MORE INFORMATION ABOUT OUR PRODUCTS, VISIT
WWW.INVACARE.COM



NO POSTAGE
NECESSARY
IF MAILED
IN THE
UNITED STATES

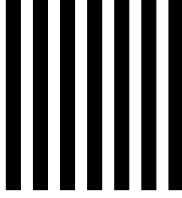

BUSINESS REPLY MAIL

FIRST-CLASS MAIL PERMIT NO. 196 ELYRIA OH

POSTAGE WILL BE PAID BY ADDRESSEE

INVACARE CORPORATION
CRM DEPARTMENT
39400 TAYLOR PARKWAY
ELYRIA OH 44035-9836



SECTION 4—COMPRESSOR OPERATION

Connecting/Disconnecting the Cylinder to/from the Compressor

Connecting the Cylinder to the Compressor

⚠ WARNING

NEVER use tools of any kind to connect/disconnect the cylinder and the compressor. Otherwise, severe injury and/or damage may occur.

DO NOT drop oxygen cylinders. Use two hands when handling/transporting oxygen cylinders. Otherwise, injury or damage may occur.

DO NOT use a liquid leak detector to test for leaks.

NOTE: For this procedure, refer to FIGURE 4.1 on page 24 and FIGURE 4.2 on page 26.

1. Examine the cylinder gauge. If the cylinder pressure is **less** than 1500 psig, proceed to STEP 2 (FIGURE 4.2).

*NOTE: If the cylinder pressure is **greater** than 1500 psig., DO NOT attempt to top off this cylinder. It may not fill.*

2. Set the regulator flow dial on the cylinder to Off (FIGURE 4.2).
3. Remove the cylinder and connector fillport covers (if present).

CAUTION

DO NOT connect the outlet (cannula) connection to the HomeFill II compressor, otherwise the conserving cylinder will not work properly.

4. Momentarily push DOWN on the outer ring (sleeve) of the connector fillport until GREEN dots are visible to reset the connector (FIGURE 4.1).

NOTE: If the outer ring (sleeve) is in the UP position (GREEN dots not visible), the connector fillport will not be able to accept the cylinder fillport. Pushing DOWN momentarily will reset the connector fillport (GREEN dots visible) to accept the cylinder fillport.

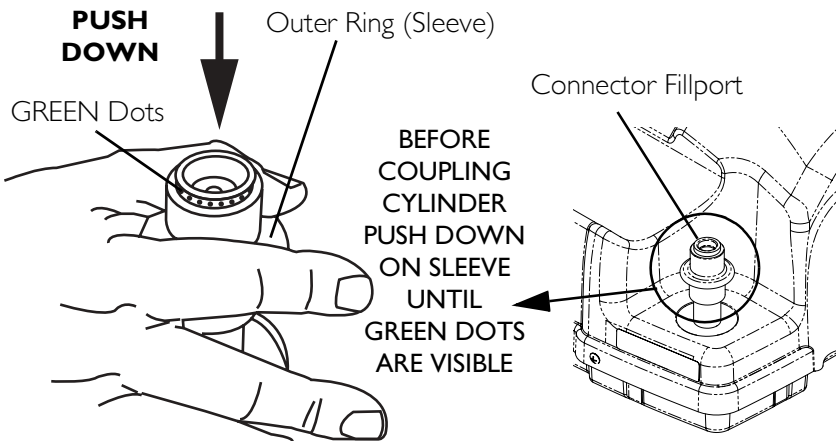

FIGURE 4.1 Resetting Connector Fillport

5. Grasp the cylinder/regulator assembly in the area behind the cylinder gauge (FIGURE 4.2).
6. Position the cylinder in the compressor cradle (FIGURE 4.2).
7. Align the cylinder fillport with the connector fillport (FIGURE 4.2).

8. Pull UP on the outer ring (sleeve) of the connector fillport while pushing DOWN on the cylinder/regulator assembly to couple the cylinder fillport into the connector fillport (FIGURE 4.2).

NOTE: The cylinder is properly connected when an audible “click” is heard.

SECTION 4—COMPRESSOR OPERATION

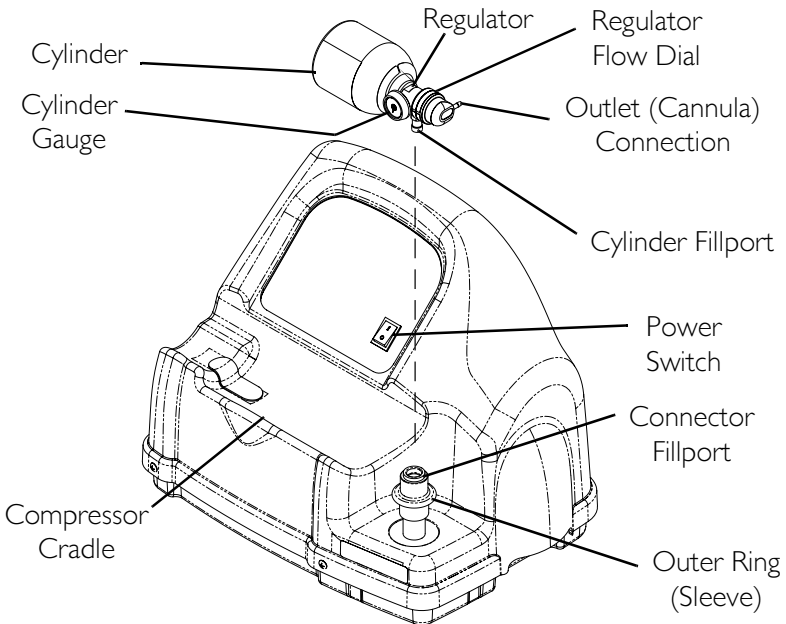
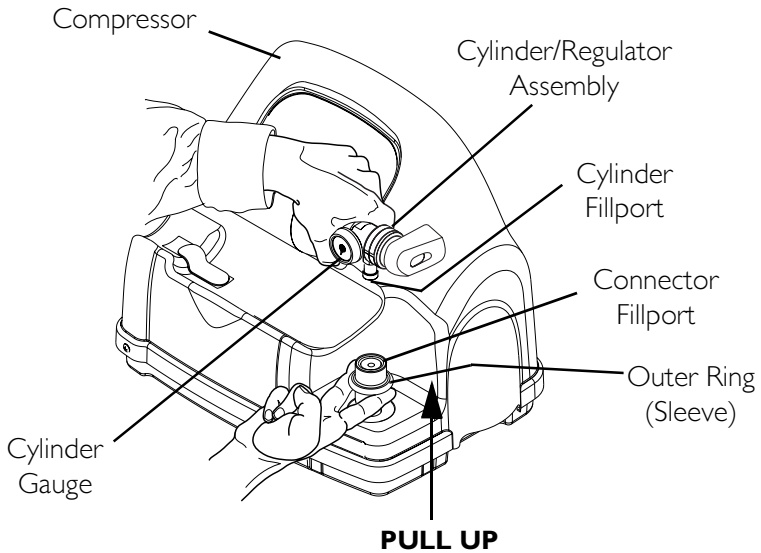

NOTE: Fillport covers not shown for clarity.

FIGURE 4.2 Connecting the Cylinder to the Compressor

Disconnecting the Cylinder from the Compressor

⚠ WARNING

NEVER use tools of any kind to connect/disconnect the cylinder and the compressor. Otherwise, severe injury and/or damage may occur.

NOTE: For this procedure, refer to FIGURE 4.3.

1. Press the compressor power switch to the Off (O) position.
2. Grasp the cylinder/regulator assembly in the area behind the cylinder gauge.
3. With the other hand, grasp the outer ring (sleeve) of the connector fillport and push DOWN.
4. Lift up on the cylinder/regulator assembly to remove from the connector fillport.

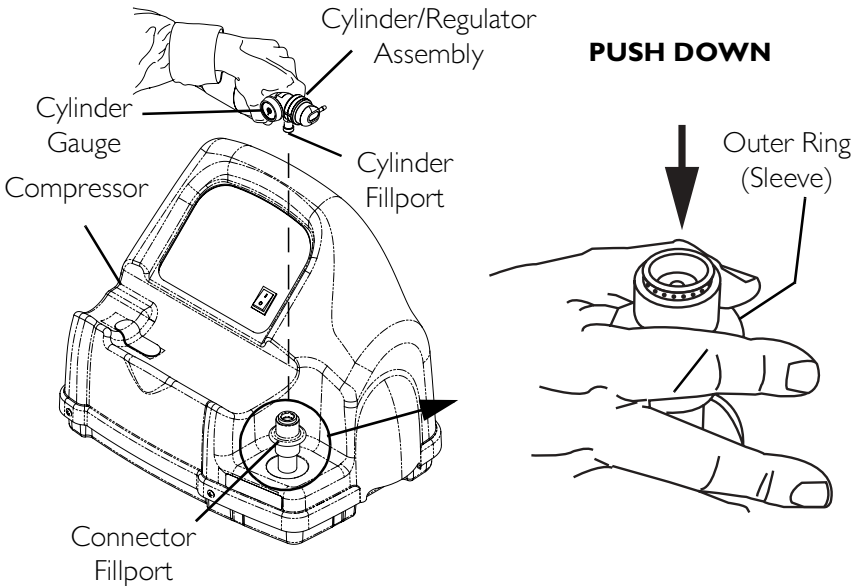

FIGURE 4.3 Disconnecting the Cylinder from the Compressor

- When the cylinder fillport is disconnected from the connector fillport, release the outer ring (sleeve) of the connector fillport and use two hands to remove the cylinder from the compressor cradle.

⚠ WARNING

The fillport cover on the connector fillport and the cylinder fillport MUST be replaced after filling and whenever not in use. If either of the fillport covers are missing contact your healthcare provider before using.

- Place the fillport covers onto the connector fillport and cylinder fillport.
- Examine the cylinder gauge to ensure cylinder is full (needle pointing into GREEN area). If the cylinder is not full, perform the following:
 - Repeat Connecting the Cylinder to the Compressor on page 23.
 - If cylinder is not full after second attempt to fill, contact the provider.

Cylinder Fillport Cover

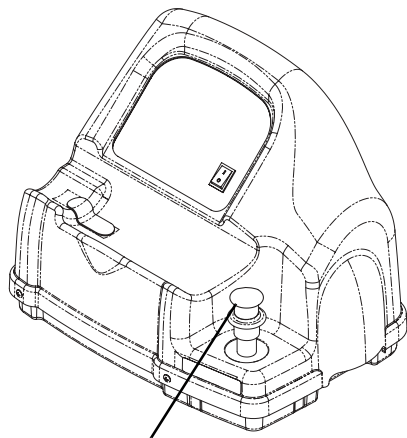
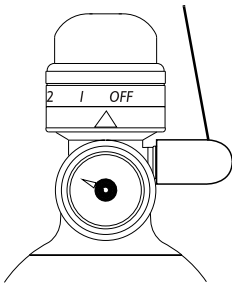

Connector Fillport Cover

FIGURE 4.4 Fillport Covers

Turning the Compressor On

NOTE: For this procedure, refer to FIGURE 4.5 on page 30.

1. Make sure the concentrator is On. Refer to the concentrator Owner's Manual.

CAUTION

The concentrator flow rate to the patient **MUST be set at maximum: 3 L/min. or less for Platinum 5, XL and 5 L/min. for Platinum 10. Otherwise, the oxygen level to the compressor will be <90% and the compressor will not fill the cylinder.**

2. Set the concentrator flow rate to the patient to 3 L/min. or less for Platinum 5, XL and 5 L/min. for Platinum 10. Refer to the concentrator Owner's Manual.
3. Make sure the cylinder is connected to the compressor. Refer to Connecting the Cylinder to the Compressor on page 23.
4. Push the power switch on the control panel to the On (I) position.
5. Examine the control panel. The following sequence of events should occur:
 - A. 0-3 minutes - The O₂ Below Normal (YELLOW) light will be lit while the compressor warms up.
 - B. After three minutes - The FILLING (GREEN) light will be on while the cylinder is filling.
 - C. The FULL (GREEN) light will be on when the cylinder is finished filling. Proceed to STEP 6.

NOTE: The O₂ BELOW NORMAL (YELLOW) light may come on if the oxygen level from the concentrator has not yet reached or drops below 90%. The compressor will begin or resume filling when the

oxygen level reaches 90%. If light does not go Off within 10 minutes, refer to Troubleshooting/ Cylinder Fill times on page 34.

NOTE: If the ATTENTION (RED) light and audible alarm are on. Refer to Troubleshooting/ Cylinder Fill times on page 34.

6. Remove the full cylinder. Refer to Disconnecting the Cylinder from the Compressor on page 27.
7. Push the power switch to the Off (O) position.

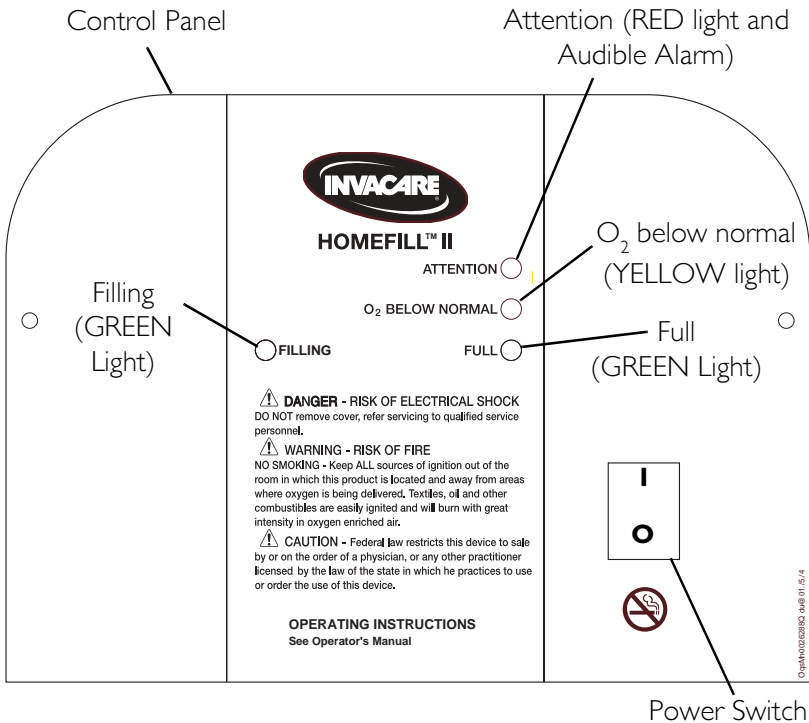

FIGURE 4.5 Turning the Compressor On

Setting the Flow Knob to the Prescribed Setting

NOTE: For this procedure, refer to FIGURE 4.6.

1. Attach the nasal cannula to the outlet fitting of the cylinder.
2. Turn the flow knob to the L/min. setting prescribed by your physician or therapist.

⚠ WARNING

As changing the L/min. setting on the flow knob will affect the dose of oxygen delivered, DO NOT readjust the L/min. setting unless directed by your physician or therapist.

3. To turn the flow of oxygen Off, turn the flow knob counter-clockwise to the Off position.

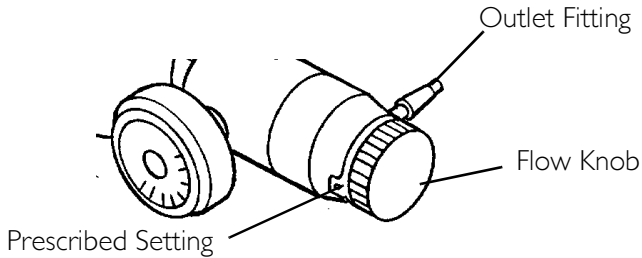

FIGURE 4.6 Setting the Flow Knob to the Prescribed Setting

SECTION 5—INDICATOR LIGHTS

INDICATOR LIGHT COLOR	COMPRESSOR STATUS	EFFECT
None	Compressor is Off	O ₂ flowing to user if concentrator is on
O ₂ BELOW NORMAL - YELLOW	Compressor is On and warming up (0-3 minutes after power is On)	Cylinder filling not started
		O ₂ flowing to user if concentrator is On
	O ₂ from concentrator is < 90% (any time after three minute warmup)	Cylinder filling stops, will restart when O ₂ > 90%
		O ₂ flowing to user if concentrator is On
FILLING - GREEN	Compressor is On and cylinder is filling. O ₂ from concentrator is >90% (any time after three minute warmup)	Cylinder is filling
		O ₂ flowing to user if concentrator is On
FULL - GREEN	Compressor is On. Cylinder is finished filling (full) -remove cylinder (FULL light is On in >10 mins.) or Cylinder is not attached properly - check connection (FULL light is On in <10 mins.)	Cylinder filling stops Cannot fill another cylinder until compressor is turned Off and On again O ₂ flowing to user if concentrator is On

SECTION 5—INDICATOR LIGHTS

INDICATOR LIGHT COLOR	COMPRESSOR STATUS	EFFECT
ATTENTION - RED (Audible Alarm)	Compressor is On. Cylinder NOT filling Causes: Full cylinder attached when unit turned On - replace with empty cylinder or Internal failure - contact dealer	Compressor does not begin to fill or stops filling Unit must be turned Off and On before filling can occur O ₂ flowing to user if concentrator is On

SECTION 6—TROUBLESHOOTING/ CYLINDER FILL TIMES

TROUBLESHOOTING	
PROBLEM	SOLUTION
No indicator lights on when compressor turned on.	<ol style="list-style-type: none"> 1. Turn compressor Off. 2. Check that power cord is properly plugged into compressor and wall outlet. 3. Turn the compressor On. 4. Clean air filters. Refer to <u>Maintenance</u> on page 37. 5. If performing STEPS 1-4 does not cause any indicator lights to come on, contact your home health care provider or Invacare for service.
RED Light ON	<ol style="list-style-type: none"> 1. Check the cylinder gauge to see if it is FULL. Cylinder full - Remove the cylinder and turn the unit Off. Perform the <u>Cylinder Prefill Inspection</u> on page 16 with a cylinder that is NOT FULL. Cylinder not full - Proceed to STEP 2. 2. Check that the cylinder is connected properly. Turn the compressor Off. Remove the cylinder and reinstall. Turn the compressor On. 3. If cylinder is not full and is connected properly, the compressor may have internal failure. Contact your home health care provider or Invacare.
Compressor cycles ON and Off or O ₂ BELOW NORMAL (YELLOW) and FILLING (GREEN) lights are alternating or O ₂ BELOW NORMAL (YELLOW) light goes On and Off	<ol style="list-style-type: none"> 1. Check the concentrator liter flow setting is at 3 L/min. or less. If necessary, adjust the liter flow setting (refer to the concentrator owner's manual). Wait at least 20 minutes for the GREEN light to appear. If it does not appear, proceed to STEP 2. 2. The concentrator may need service, contact your home health care provider or Invacare.

TROUBLESHOOTING	
PROBLEM	SOLUTION
<p>O₂ BELOW NORMAL (YELLOW) light stays On</p>	<ol style="list-style-type: none"> 1. Ensure the concentrator has warmed up for at least 20 minutes. If it has not been 20 minutes, turn the compressor Off until the concentrator warms up. If the YELLOW light still remains on proceed to STEP 2. 2. Inspect the connection between the compressor and the concentrator for damage or pinching. If damaged, replace. If pinched, straighten tubing. Turn the compressor Off for at least 10 seconds. Turn the compressor On. If the YELLOW light still remains on after 10 minutes, proceed to STEP 3. 3. The concentrator may need service, contact your home health care provider or Invacare.
<p>Fill times exceed maximum as recommended fill times OR GREEN filling light stays On.</p>	<ol style="list-style-type: none"> 1. Ensure the cylinder regulator is set to Off. 2. Check the recommended fill times shown in <i>Cylinder Fill Times</i> on page 36. 3. Check that the cylinder is connected properly. Turn the compressor Off. Remove the cylinder and reinstall. Turn the compressor ON. 4. Check the compressor/concentrator line for proper connection and/or damage (i.e. - leaks or kinks). 5. Check the concentrator liter flow setting is at three L/min. or less. If necessary, adjust the liter flow setting (refer to the concentrator owner's manual). If the GREEN filling light does not go Off, the compressor and/or concentrator may need service. Contact your home health care provider or Invacare.
<p>Excessive noise when compressor is On</p>	<ol style="list-style-type: none"> 1. Call home health care provider or Invacare for service.
<p>Hissing sound from Regulator when flow selector is Off</p>	<ol style="list-style-type: none"> 1. Turn flow selector Off. 2. If hissing sounds continue, call home health care provider or Invacare.

SECTION 6—TROUBLESHOOTING/ CYLINDER FILL TIMES

TROUBLESHOOTING	
PROBLEM	SOLUTION
Regulator is On but O ₂ is not being delivered	<ol style="list-style-type: none"> 1. Refill cylinder 2. Check that cannula is straight and not pinched. If damaged, replace. 3. Call home health care provider or Invacare for service.

CYLINDER FILL TIMES			
Cylinder Filling Times	Concentrator Flow Rate to Patient: (Platinum 5 up to 3 L/min. and Platinum 10 up to 5 L/min)		
	HF2PC9	HF2PCL4	HF2PCL6
NORMAL	2 hr 20 min	60 min	1 hr 25 min
MAXIMUM	2 hr 45 min	1 hr 20 min	1 hr 50 min

NOTE: All filling times are approximate and may vary on environmental conditions.

SECTION 7—MAINTENANCE

Cleaning the Compressor Filter

⚠ WARNING

Push the power switch to the **Off (O)** position and unplug the compressor before cleaning.

DO NOT operate the compressor without the filter installed.

CAUTION

DO NOT unplug by pulling on cord. To unplug, grasp the plug not the cord, otherwise damage may occur.

NOTE: For this procedure, refer to FIGURE 7.1.

NOTE: All compressors have one filter on the back of the cabinet.

NOTE: Perform this procedure at least once a week.

1. Unplug the compressor. Grasp the plug not the cord.
2. Remove the filter.
3. Clean the filter with a vacuum cleaner or wash in warm soapy water and rinse thoroughly.
4. Dry the filter thoroughly before reinstallation.

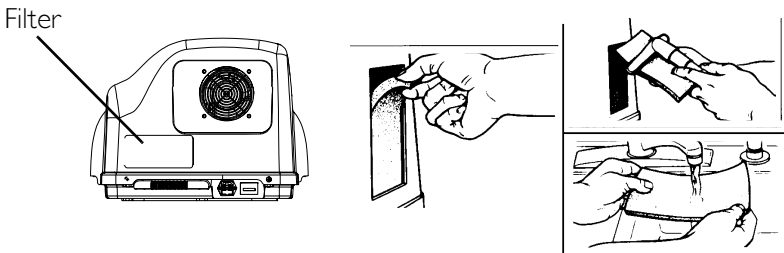

FIGURE 7.1 Cleaning the Compressor Filter

Cabinet

⚠ WARNING

Push the power switch to the Off (O) position and unplug the compressor before cleaning. To avoid electrical shock, DO NOT remove cabinet.

1. Clean the cabinet with a mild household cleaner and non-abrasive cloth or sponge.

LIMITED WARRANTY

NOTE: THE WARRANTY BELOW HAS BEEN DRAFTED TO COMPLY WITH FEDERAL LAW APPLICABLE TO PRODUCTS MANUFACTURED AFTER JULY 4, 1975.

This warranty is extended only to original purchaser who purchases this product when new and unused from Invacare Corporation or a dealer. This warranty is not extended to any other person or entity and is not transferable or assignable to any subsequent purchaser or owner. Coverage under this warranty will end upon any such subsequent sale or other transfer of title to any other person. This warranty gives you specific legal rights and you may also have other legal rights which may vary from state to state.

Invacare warrants the HomeFill II Compressor to be free from defects in materials and workmanship for a period of one (1) year from date of purchase from Invacare or a dealer, with a copy of the seller's invoice required for coverage under this warranty.

Invacare warrants the HomeFill II internal wear components (piston seals and rings, bearings, drive belts, check valves, pressure relief components and electric motor) for a period of three (3) years from the date of purchase from Invacare or a dealer, with a copy of the seller's invoice required for coverage under this warranty, or 5,000 hours, whichever comes first.

Invacare warrants the HomeFill II control panel components (electrical switches, reset switch and indicator lights) for a period of three (3) years from the date of purchase from Invacare or a dealer, with a copy of the seller's invoice required for coverage under this warranty, or 5,000 hours, whichever comes first.

For Model Nos. IOH2M6 and IOH2M9, Invacare warrants the HomeFill II regulator (NOT including the cylinder) to be free from defects in materials and workmanship for a period of six (6) years from date of purchase from Invacare or a dealer, with a copy of the seller's invoice required for coverage under this warranty.

For Model Nos. HF2PCL4, HF2PCL6 and HF2PC9, Invacare warrants the HomeFill II regulator (NOT including the cylinder) to be free from defects in materials and workmanship for a period of two (2) years from date of purchase from Invacare or a dealer, with a copy of the seller's invoice required for coverage under this warranty

DO NOT OPEN OR ATTEMPT TO SERVICE UNLESS SERVICE IS PROVIDED BY AN INVACARE-CERTIFIED TECHNICIAN; otherwise, this will void any and all warranties. If within such warranty periods any such product shall be proven to Invacare's satisfaction to be defective, such product shall be repaired or replaced, at Invacare's option. This warranty only applies to the labor for repairs performed by the Invacare Service Department or Invacare dealers. It does not apply to the labor performed by the purchaser or user. This warranty does not include normal wear and tear, failure to adhere to the product instructions, or shipping charges incurred in replacement part installation or repair of any such product. Invacare's sole obligation and your exclusive remedy under this warranty shall be limited to such repair or replacement. Routine maintenance items, such as filters, are excluded from this warranty.

For warranty service, please contact Invacare's service department at the toll free number on the back page during normal working hours.

Upon receiving notice of an alleged defect in a product, Invacare will issue a serialized return authorization. It shall be the responsibility of the purchaser, at the purchaser's cost, to return the unit, pack the unit in a manner to avoid shipping damage and to ship the unit to either Invacare's plant or service center as specified by Invacare in advance. Defective units must be returned for warranty inspection using the serial number as identification within thirty (30) days of return authorization date. Do not return products to our factory without prior consent. C.O.D. shipments will be refused; please prepay shipping charges.

LIMITATIONS AND EXCLUSIONS: THE FOREGOING WARRANTY SHALL NOT APPLY TO PRODUCTS SUBJECTED TO NEGLIGENCE, ACCIDENT, IMPROPER OPERATION, MAINTENANCE OR STORAGE, SOOT OR SMOKE-FILLED ENVIRONMENTS, OR OTHER THAN NORMAL APPLICATION, USE OR SERVICE, OR TO PRODUCTS MODIFIED WITHOUT INVACARE CORPORATION'S EXPRESS WRITTEN CONSENT

(INCLUDING, BUT NOT LIMITED TO, MODIFICATION THROUGH THE USE OF UNAUTHORIZED PARTS OR ATTACHMENTS) OR TO PRODUCTS DAMAGED BY REASON OF REPAIRS MADE TO ANY COMPONENT WITHOUT THE SPECIFIC CONSENT OF INVACARE CORPORATION OR TO PRODUCTS DAMAGED BY CIRCUMSTANCES BEYOND INVACARE CORPORATION'S CONTROL.

THE FOREGOING EXPRESS WARRANTY IS EXCLUSIVE AND IN LIEU OF ANY OTHER WARRANTIES WHATSOEVER, WHETHER EXPRESS OR IMPLIED, INCLUDING THE IMPLIED WARRANTIES OF MERCHANTABILITY AND FITNESS FOR A PARTICULAR PURPOSE, AND THE SOLE REMEDY FOR VIOLATIONS OF ANY WARRANTY WHATSOEVER, SHALL BE LIMITED TO REPAIR OR REPLACEMENT OF THE DEFECTIVE PRODUCT PURSUANT TO THE TERMS CONTAINED HEREIN. THE APPLICATION OF ANY IMPLIED WARRANTY WHATSOEVER SHALL NOT EXTEND BEYOND THE DURATION OF THE EXPRESS WARRANTY PROVIDED HEREIN. INVACARE SHALL NOT BE LIABLE FOR ANY CONSEQUENTIAL OR INCIDENTAL DAMAGES WHATSOEVER.

SOME STATES DO NOT ALLOW THE EXCLUSION OR LIMITATION OF INCIDENTAL OR CONSEQUENTIAL DAMAGE, OR LIMITATION OF HOW LONG AN IMPLIED WARRANTY LASTS, SO THE ABOVE EXCLUSION AND LIMITATION MAY NOT APPLY TO YOU.

THIS WARRANTY SHALL BE EXTENDED TO COMPLY WITH STATE/PROVINCIAL LAWS AND REQUIREMENTS.

Invacare Corporation

www.invacare.com



Yes, you can.

USA
One Invacare Way
Elyria, Ohio USA
44036-2125
800-333-6900

Technical Services
800-832-4707

Invacare, the Medallion Design, Yes, You Can. are registered trademarks of Invacare Corporation. Platinum and HomeFill are trademarks of Invacare Corporation
© 2006 Invacare Corporation.

Part No 1100873
Rev G - 11/01/06